

STEERING SYSTEM

SECTION **ST**

CONTENTS

PRECAUTIONS	ST- 2
PREPARATION	ST- 3
ON-VEHICLE INSPECTION	ST- 5
ON-VEHICLE INSPECTION (Power steering)	ST- 7
STEERING WHEEL AND STEERING COLUMN	ST-10
POWER STEERING GEAR AND LINKAGE (Model PR24SC and PR26SC)	ST-15
POWER STEERING OIL PUMP	ST-28
SERVICE DATA AND SPECIFICATIONS (S.D.S.)	ST-32

ST

PRECAUTIONS

- Before disassembly, thoroughly clean the outside of the unit.
- Disassembly should be done in a clean work area. It is important to prevent the internal parts from becoming contaminated by dirt or other foreign matter.
- When disassembling parts, be sure to place them in order in a parts rack so they can be reinstalled in their proper positions.
- Use nylon cloths or paper towels to clean the parts; common shop rags can leave lint that might interfere with their operation.
- Before inspection or reassembly, carefully clean all parts with a general purpose, non-flammable solvent.
- Before assembly, apply a coat of recommended A.T.F.* to hydraulic parts. Vaseline may be applied to O-rings and seals. Do not use any grease.
- Replace all gaskets, seals and O-rings. Avoid damaging O-rings, seals and gaskets during installation. Perform functional tests whenever designated.

*: Automatic transmission fluid

PREPARATION

SPECIAL SERVICE TOOLS

*: Special tool or commercial equivalent

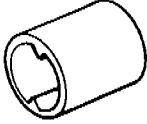
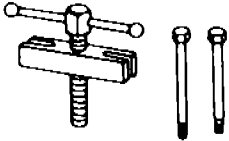
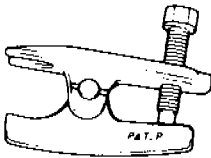
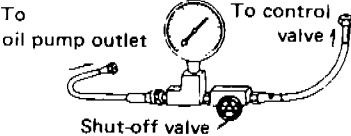
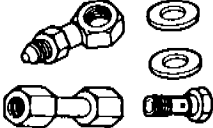
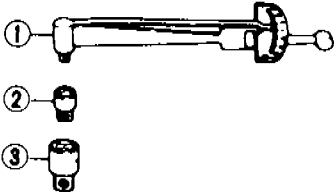
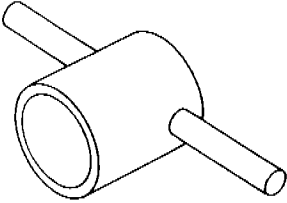
Tool number Tool name	Description	Measuring pinion rotating torque
KV48100700 Torque adapter		
ST27180001* Steering wheel puller		Removing and installing steering wheel
HT72520000* Ball joint remover		Removing ball joint
ST27091000* Pressure gauge		Measuring oil pressure
KV48102500 Pressure gauge adapter		Measuring oil pressure
ST3127S000* ① GG91030000 Torque wrench ② HT62940000 Socket adapter ③ HT62900000 Socket adapter		Measuring turning torque
KV48104400 Rack seal ring reformer		Reforming teflon ring

PREPARATION

COMMERCIAL SERVICE TOOLS

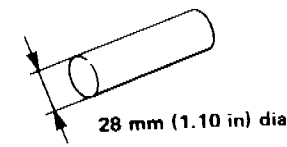
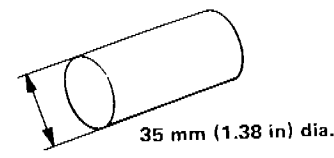
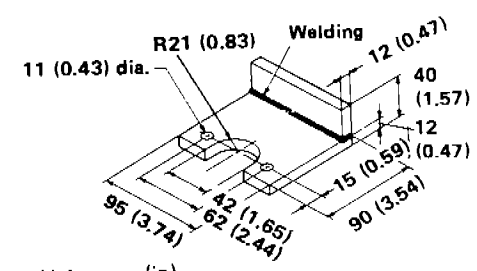
Tool name	Description
Rear oil seal drift	 <p style="text-align: center;">28 mm (1.10 in) dia.</p> <p style="text-align: right;">Installing rear oil seal</p>
Pinion oil seal drift	 <p style="text-align: center;">35 mm (1.38 in) dia.</p> <p style="text-align: right;">Installing pinion oil seal</p>
Oil pump attachment	 <p style="text-align: center;">Unit: mm (in) SST481A</p> <p style="text-align: right;">Disassembling and assembling oil pump</p>

ON-VEHICLE INSPECTION

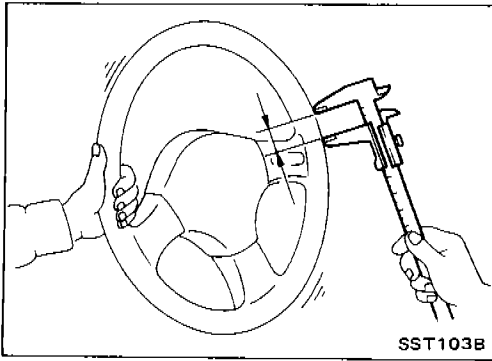

Checking Steering Wheel Play

- With wheels in a straight-ahead position, check steering wheel play.

Steering wheel play:

35 mm (1.38 in) or less

- If it is not within specification, check rack and pinion assembly.

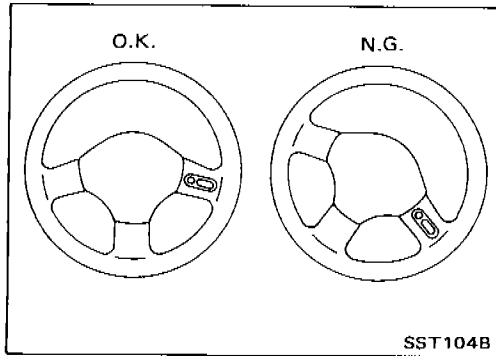

Checking Neutral Position on Steering Wheel

Pre-checking

- Verify that the steering gear is centered before removing the steering wheel.

Checking

- Check that the steering wheel is in the neutral position when driving straight ahead.
- If it is not in the neutral position, remove the steering wheel and reinstall it correctly.
- If the neutral position is between two serrated teeth, loosen tie-rod lock nut and move tie-rod in the opposite direction by the same amount on both left and right sides to compensate for error in the neutral position.

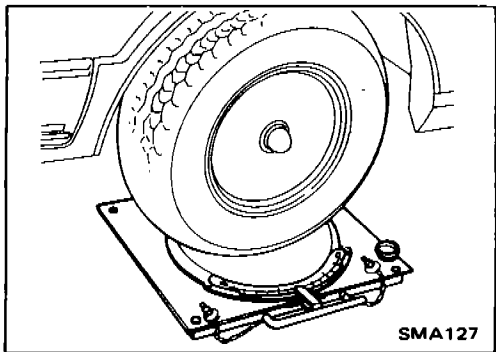

Front Wheel Turning Angle

- Rotate steering wheel all the way right and left; measure turning angle.

Turning angle of full turns:

Refer to section FA for S.D.S.

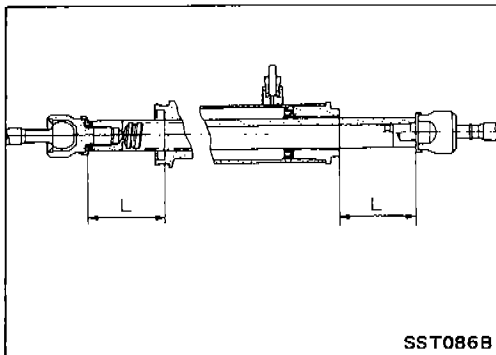

- If it is not within specification, check rack stroke.

Measured length "L":

Refer to S.D.S.

ON-VEHICLE INSPECTION

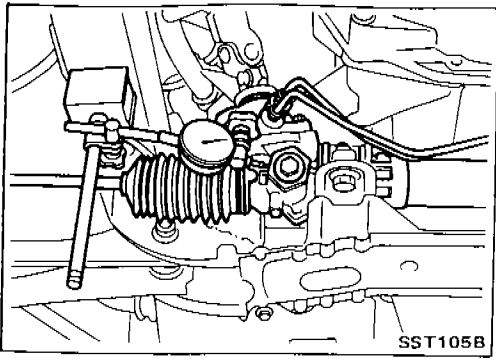

Checking Gear Housing Movement

- Check the movement of steering gear housing during stationary steering. The maximum allowable movement is as follows:

Movement of gear housing:

± 2 mm (± 0.08 in) (on dry paved surface) or less

Apply a force of 49 N (5 kg, 11 lb) to steering wheel to check the gear housing movement.

On models equipped with power steering, turn off ignition key while checking.

- If movement exceeds the limit, replace mount insulator after confirming proper installation of gear housing clamps.

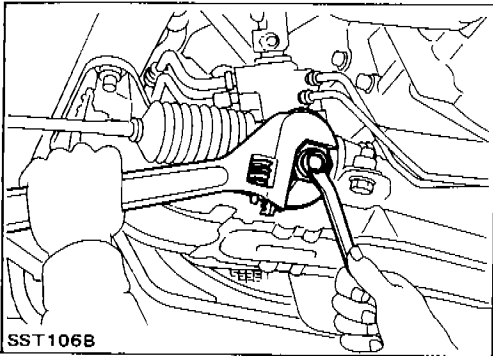

Adjusting Rack Retainer

- Perform this driving test on a flat road.
1. Check whether vehicle moves in a straight line when steering wheel is released.
 2. Check whether steering wheel returns to neutral position when steering wheel is released from a slightly turned (approx. 20°) position.
- If any abnormality is found, correct it by resetting adjusting screw.

ON-VEHICLE INSPECTION (Power steering)

Checking and Adjusting Drive Belts

Refer to section MA for Drive Belt Inspection.

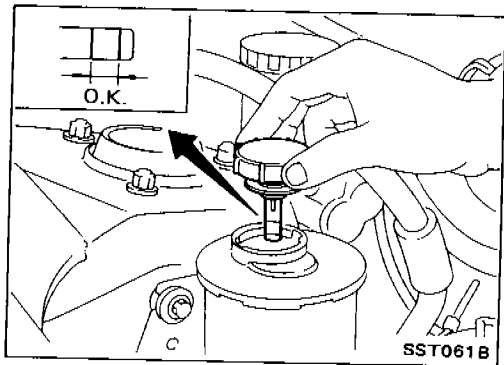

Checking Fluid Level

Check the level when the fluid is cold.

CAUTION:

- Do not overfill.
- Recommended fluid is Automatic Transmission Fluid "DEXRON™ Type".

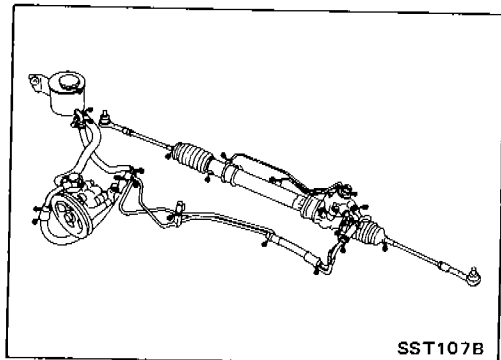

Checking Fluid Leakage

Check the lines for improper attachment and for leaks, cracks, damage, loose connections, chafing or deterioration.

1. Run engine at idle speed or 1,000 rpm.
Make sure temperature of fluid in oil tank rises to 60 to 80°C (140 to 176°F).
2. Turn steering wheel right-to-left several times.
3. Hold steering wheel at each "lock" position for five seconds and carefully check for fluid leakage.

CAUTION:

Do not hold the steering wheel in a locked position for more than 15 seconds.

4. If fluid leakage at connectors is noticed, loosen flare nut and then retighten.

Do not overtighten connector as this can damage O-ring, washer and connector.

Bleeding Hydraulic System

1. Raise front end of vehicle until wheels clear ground.
2. Add fluid into oil tank to specified level. Meanwhile, quickly turn steering wheel fully to right and left and lightly touch steering stoppers.
Repeat steering wheel operation until fluid level no longer decreases.
3. Start engine.
Repeat step 2 above.
- Incomplete air bleeding will cause the following to occur.
When this happens, bleed air again.

ON-VEHICLE INSPECTION (Power steering)

Bleeding Hydraulic System (Cont'd)

- Generation of air bubbles in reservoir tank
- Generation of clicking noise in oil pump
- Excessive buzzing in oil pump

While the vehicle is stationary or while turning the steering wheel slowly, fluid noise may occur in the valve or oil pump. This noise is inherent in this steering system, and it will not affect performance or durability of the system.

Checking Steering Wheel Turning Force

- Park vehicle on a level, dry surface and set parking brake.
- Start engine.
- Warm up power steering fluid to adequate operating temperature.

Temperature of fluid:

Approximately 60 - 80°C (140 - 176°F).

Tires need to be inflated to normal pressure.

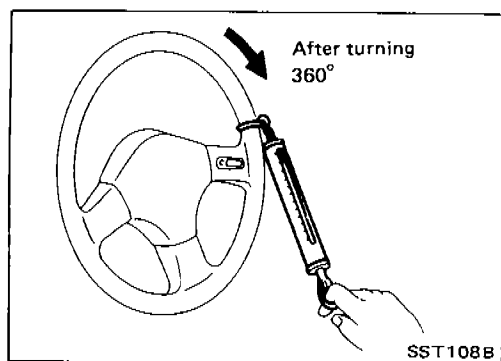

- Check steering wheel turning force with engine idling when steering wheel has been turned 360° from neutral position.

Steering wheel turning force:

39 N (4 kg, 9 lb) or less

Checking Hydraulic System

Before starting, check belt tension, driving pulley and tire pressure.

- Set Tool. Open shut-off valve. Then bleed air. (See "Bleeding Hydraulic System".)
- Run engine.

Make sure temperature of fluid in tank rises to 60 to 80°C (140 to 176°F).

ON-VEHICLE INSPECTION (Power steering)

Checking Hydraulic System (Cont'd)

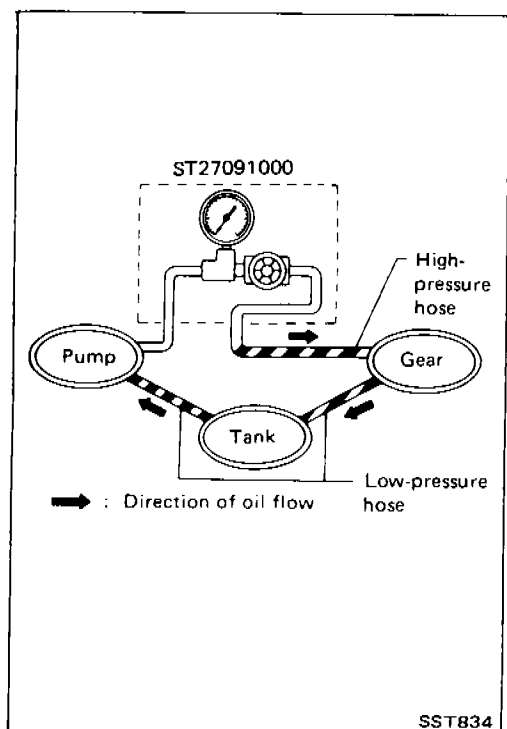

WARNING:

Warm up engine with shut-off valve fully opened. If engine is started with shut-off valve closed, oil pressure in oil pump will increase to relief pressure, resulting in an abnormal rise in oil temperature.

3. Check pressure with steering wheel fully turned to left and right positions with engine idling at 1,000 rpm.

CAUTION:

Do not hold the steering wheel in a locked position for more than 15 seconds.

Oil pump maximum standard pressure:
6,865 kPa (68.6 bar, 70 kg/cm², 995 psi)
at idling

4. If oil pressure is below the standard pressure, slowly close shut-off valve and check pressure.
 - When pressure reaches standard pressure, gear is damaged.
 - When pressure remains below standard pressure, pump is damaged.

CAUTION:

Do not close shut-off valve for more than 15 seconds.

5. If oil pressure is higher than standard pressure, pump is damaged.
6. After checking hydraulic system, remove Tool and add fluid as necessary, then completely bleed air out of system.

STEERING WHEEL AND STEERING COLUMN

L.H.D.

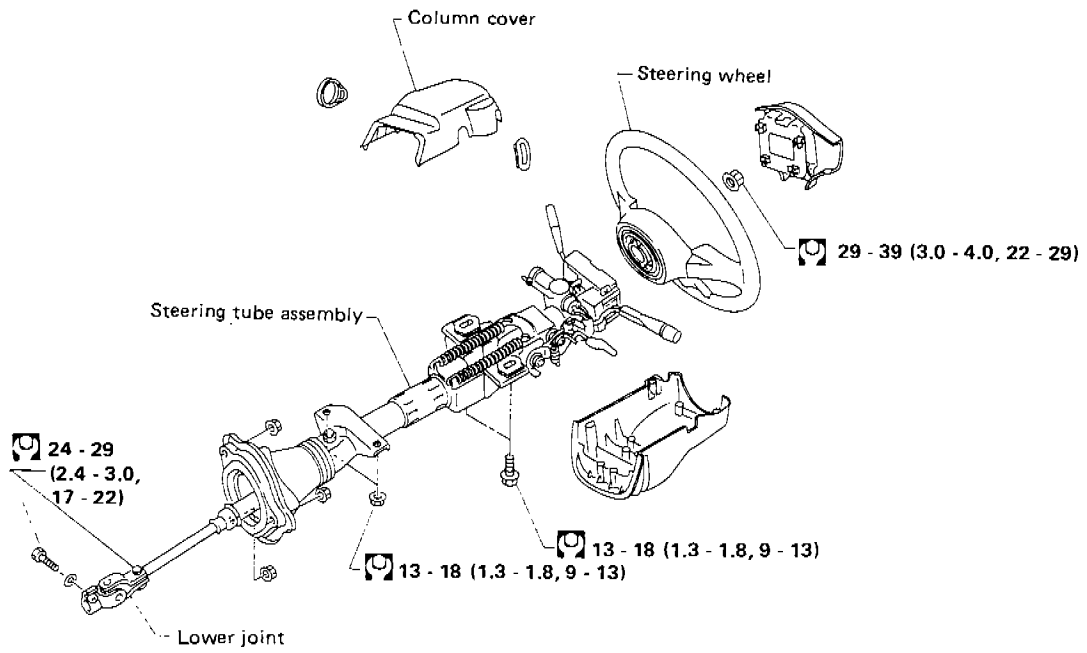

R.H.D.

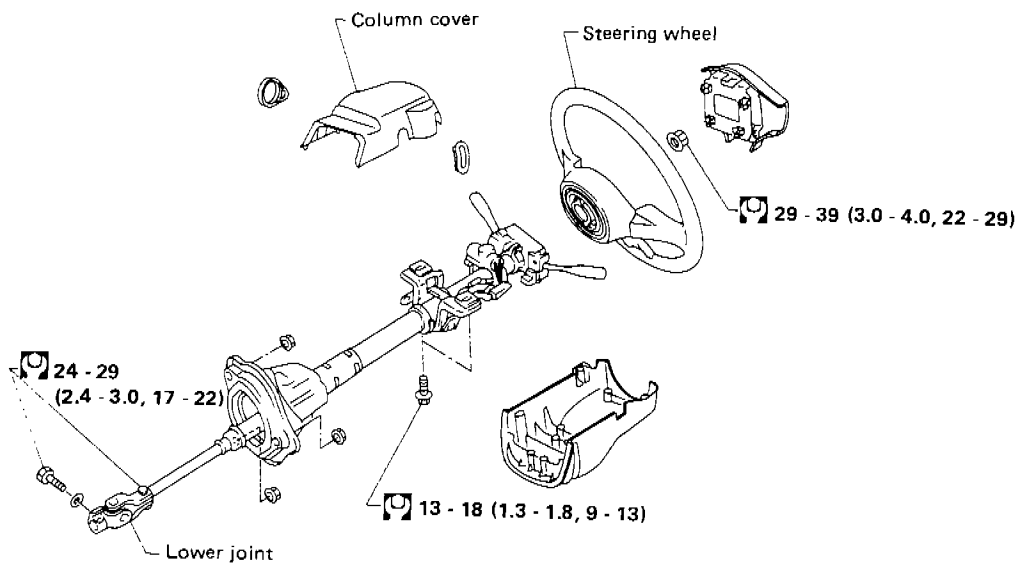

: N·m (kg·m, ft·lb)

SST144B

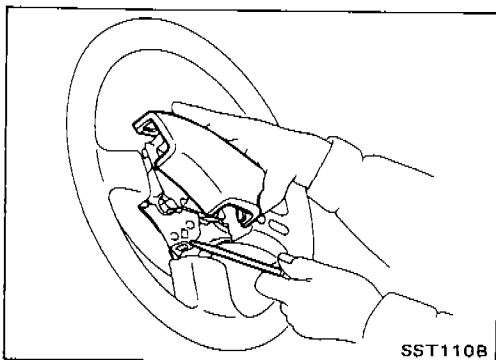

Removal

STEERING WHEEL

- Pull out horn pad.

If it is hard to pull out horn pad, temporarily loosen fixing screw of horn pad retaining spring.

STEERING WHEEL AND STEERING COLUMN

Removal (Cont'd)

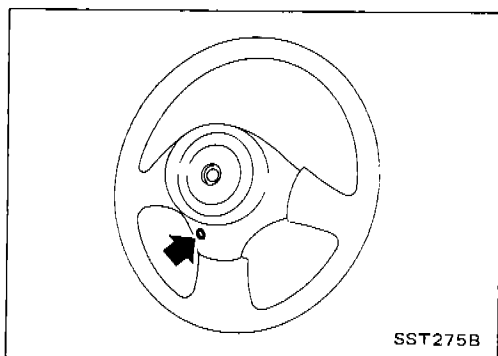

- Remove steering wheel with Tool.

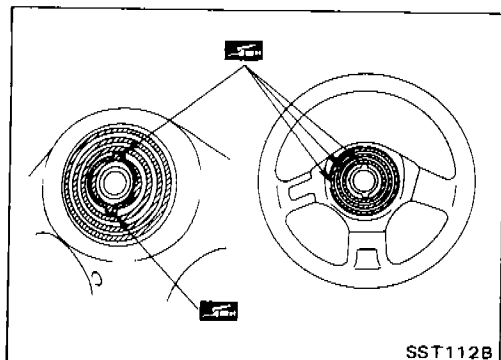
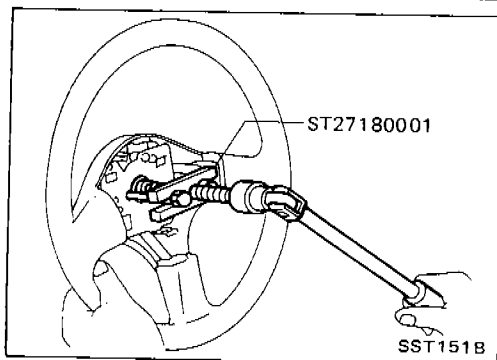

Installation

STEERING WHEEL

- When installing steering wheel, apply multi-purpose grease to entire surface of turn signal cancel pin (both portions) and also to horn contact slip ring.

STEERING COLUMN

- When installing steering column, fingertighten all lower bracket and clamp retaining bolts; then tighten them securely. Do not apply undue stress to steering column.

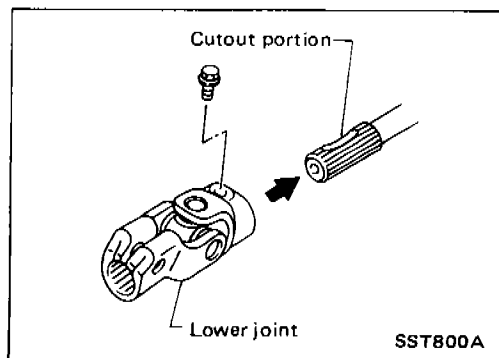

- When attaching coupling joint, be sure tightening bolt faces cutout portion.

CAUTION:

After installing steering column, turn steering wheel to make sure it moves smoothly and that the number of turns from the straight forward position to left and right locks are equal. Be sure that the steering wheel is in a neutral position when driving straight ahead.

STEERING WHEEL AND STEERING COLUMN

Disassembly and Assembly

R.H.D.

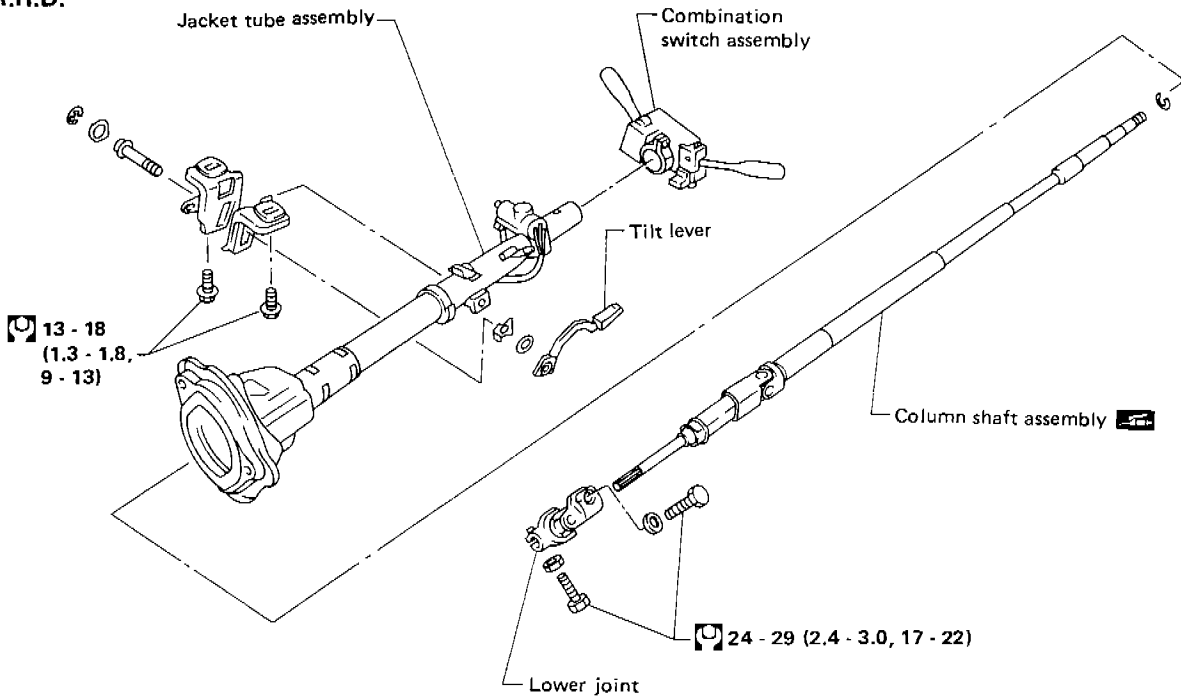

L.H.D.

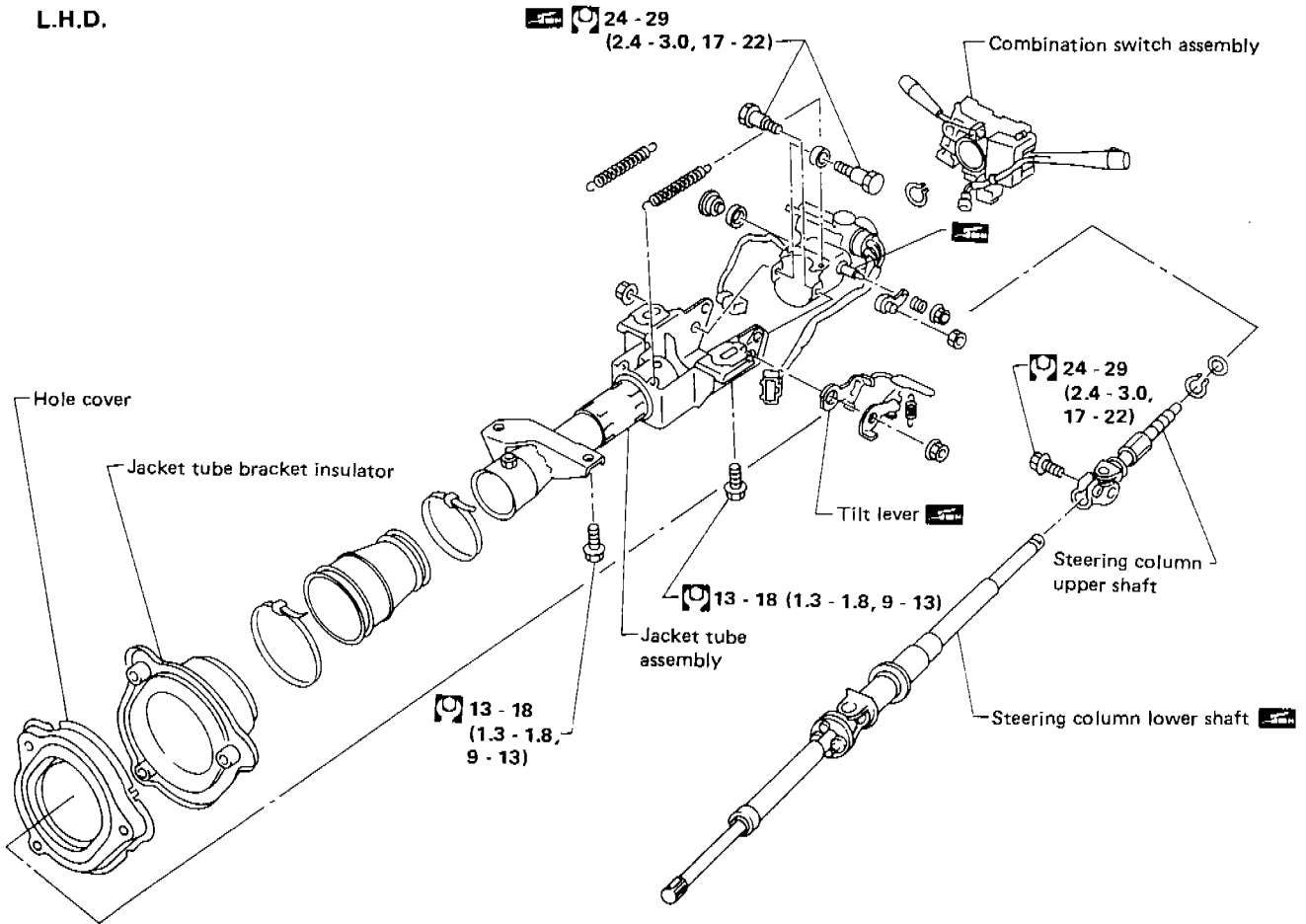

: N·m (kg·m, ft·lb)

SST145B

STEERING WHEEL AND STEERING COLUMN

Disassembly and Assembly (Cont'd)

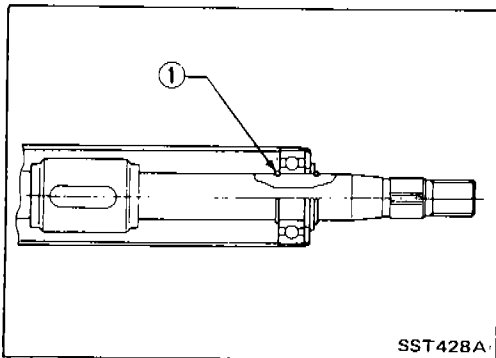

- When disassembling and assembling, unlock steering lock with key.
- Ensure that rounded surface of snap ring faces toward bearing when snap ring is installed.
- Install snap ring ① before inserting shaft into jacket tube.

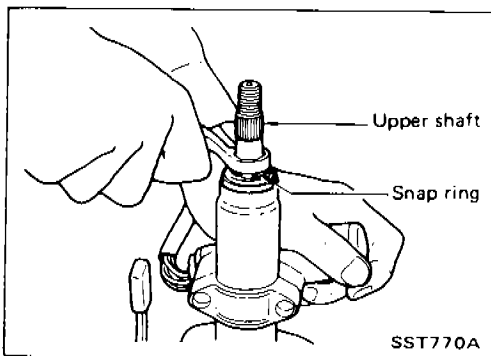

- Install snap ring on upper shaft with box wrench.

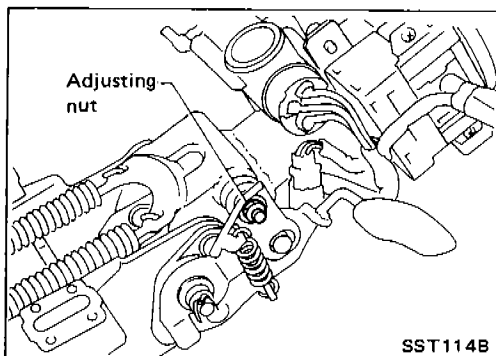

- Tilt mechanism (Jumping tilt only)
 - Tighten adjusting nut to specification.
 - : 4 - 5 N·m (0.4 - 0.5 kg-m, 2.9 - 3.6 ft-lb)

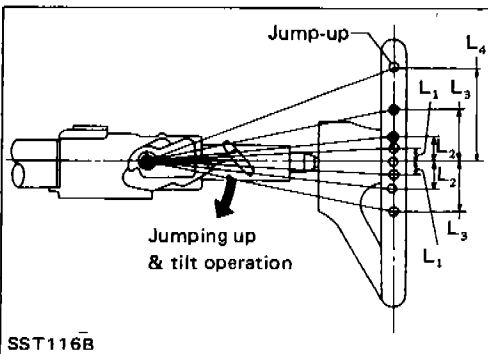

- After installing steering column, check tilt mechanism operation.

- L₁: 9.8 mm (0.386 in)
- L₂: 19.5 mm (0.768 in)
- L₃: 29.3 mm (1.154 in)
- L₄: 58.2 mm (2.291 in)

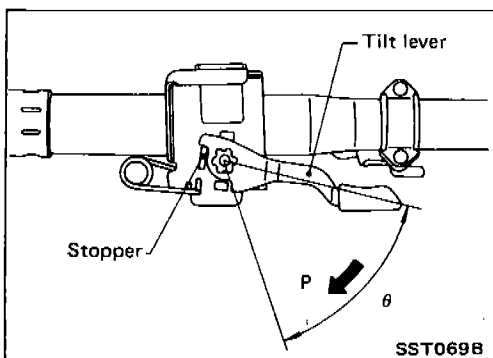

- Adjust tilt lever as follows: (R.H.D. tilt only)
 - When tilt lever contacts stopper, tighten adjusting bolt securely.
 - Turn tilt lever by 90° (θ) in direction "P" to check that steering column moves smoothly without binding.
 - Return tilt lever to position θ . Make sure there is no free play (=0) of steering column when steering wheel is pushed down by force.
 - Install lock washer and E-ring.

STEERING WHEEL AND STEERING COLUMN

Disassembly and Assembly (Cont'd)

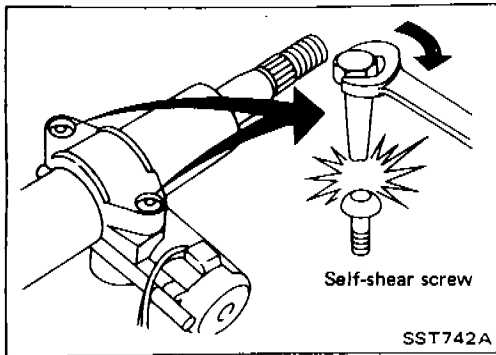

- Steering lock
- a) Break self-shear type screws with a drill or other appropriate tool.
- b) Install self-shear type screws and then cut off self-shear type screw heads.

Inspection

- When steering wheel can not be rotated smoothly, check the steering column for the following matters and replace damaged parts.
 - a. Check column bearings for damage or unevenness. Lubricate with recommended multi-purpose grease or replace steering column as an assembly, if necessary.
 - b. Check steering column lower shaft for deformation or breakage. Replace if necessary.
- When the vehicle is involved in a light collision, check steering column length " L_1 " and steering column lower shaft length " L_2 ". If it is not within specifications, replace steering column as an assembly.

R.H.D.:

Steering column length " L_1 "

715.2 - 716.8 mm (28.16 - 28.22 in)

Steering column lower shaft length " L_2 "

273.7 mm (10.78 in)

L.H.D.:

Steering column length " L_1 "

652.9 - 654.5 mm (25.70 - 25.77 in)

Steering column lower shaft length " L_2 "

324.7 mm (12.78 in)

L.H.D. and R.H.D.

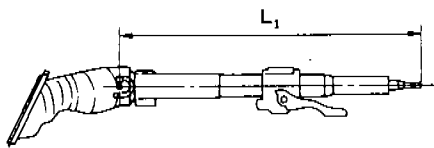

R.H.D.

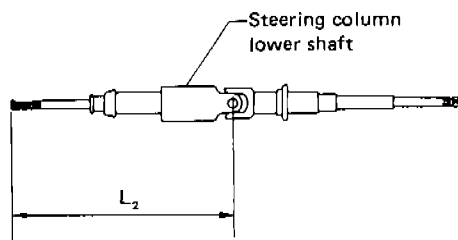

L.H.D.

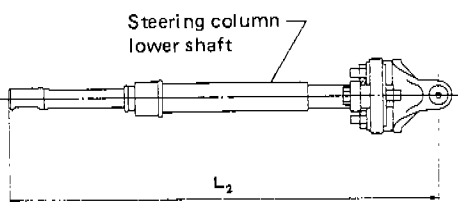

POWER STEERING GEAR AND LINKAGE (Model PR24SC and PR26SC)

Removal and Installation

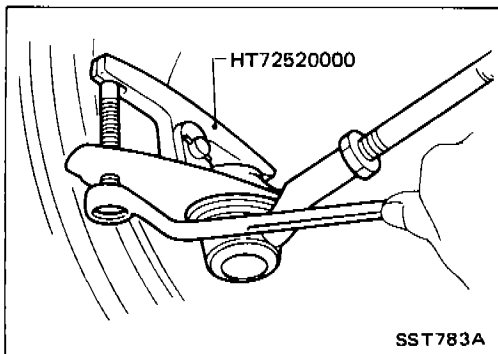
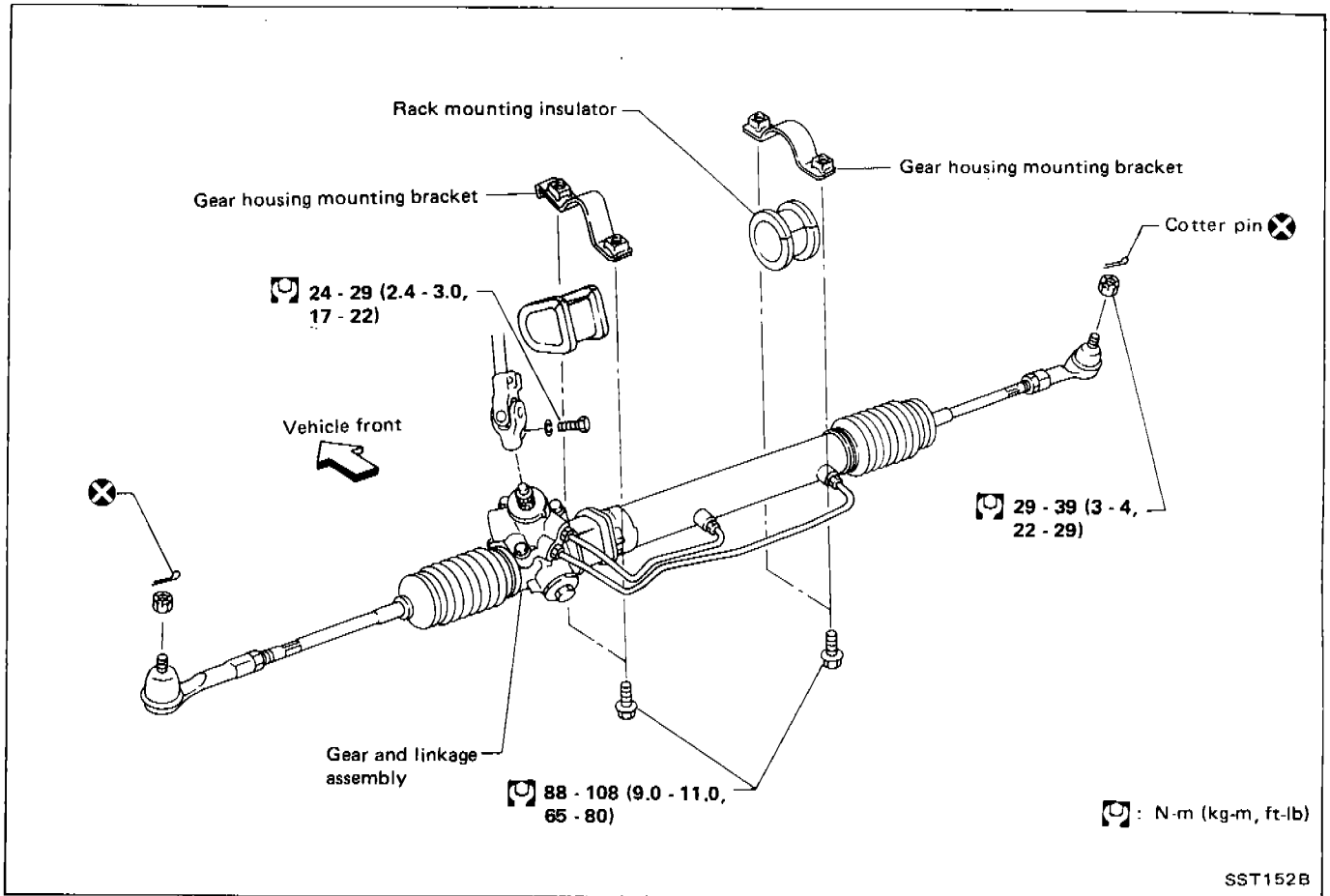

- Detach tie-rod outer sockets from knuckle arms with Tool.

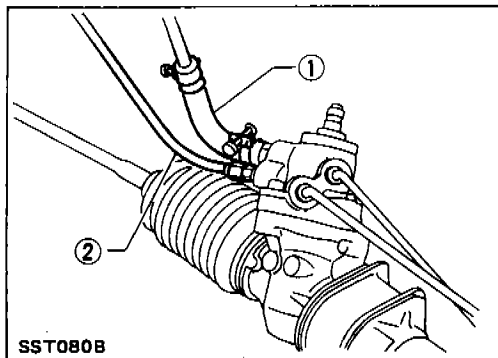

- Install pipe connector.
 - ① Low-pressure side
□: 27 - 39 N·m (2.8 - 4.0 kg·m, 20 - 29 ft·lb)
 - ② High-pressure side
□: 15 - 25 N·m (1.5 - 2.5 kg·m, 11 - 18 ft·lb)

POWER STEERING GEAR AND LINKAGE (Model PR24SC and PR26SC)

Removal and Installation (Cont'd)

- Observe specified tightening torque when tightening high-pressure and low-pressure pipe connectors. Excessive tightening can damage threads or damaged connector O-ring.
- The O-ring in low-pressure pipe connector is larger than that in high-pressure connector. Take care to install the proper O-ring.

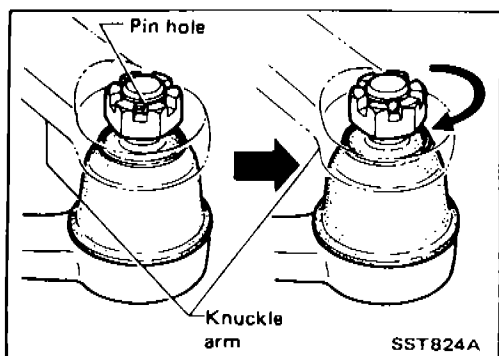

- Initially, tighten nut on tie-rod outer socket and knuckle arm to 29 to 39 N·m (3 to 4 kg-m, 22 to 29 ft-lb). Then tighten further to align nut groove with first pin hole so that cotter pin can be installed.

CAUTION:
Tightening torque must not exceed 49 N·m (5 kg-m, 36 ft-lb).

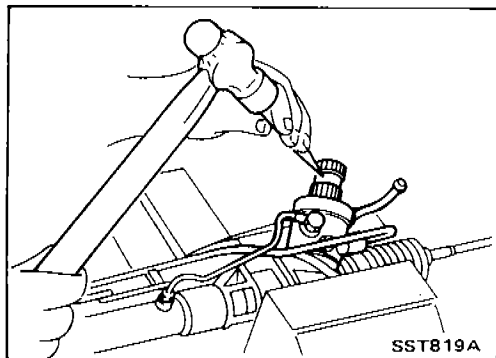

- Before removing lower joint from gear, set gear in neutral (wheels in straight-ahead position). After removing lower joint, put matching mark on pinion shaft and pinion housing to record neutral position of gear.
- To install, set left and right dust boots to equal deflection, and attach lower joint by aligning matching marks of pinion shaft and pinion housing.

POWER STEERING GEAR AND LINKAGE (Model PR24SC and PR26SC)

Disassembly and Assembly

The table below lists four ways to repair oil leaks in the steering gear, depending on the location of the leak. See the following figure for oil leak locations.

Position of oil leak Item	① Rear housing cover and rear housing	② Boot	③ Boot	④ Gear housing tube
Operation	<ul style="list-style-type: none"> ■ Replacement • Rear oil seal • Pinion oil seal • O-ring • Snap ring 	<ul style="list-style-type: none"> ■ Replacement • Rack oil seal • Boot clamp 	<ul style="list-style-type: none"> ■ Replacement • Rack oil seals • Rack oil seal • O-ring • Back-up collar • Boot clamp 	<ul style="list-style-type: none"> ■ Replacement • Gear housing tube • Copper washer
Procedure	<div style="border: 1px solid black; padding: 5px; margin-bottom: 5px;">Remove gear from vehicle.</div> <div style="border: 1px solid black; padding: 5px; margin-bottom: 5px;">Measure rack starting force and pinion rotating torque.</div> <div style="display: flex; justify-content: space-around; margin-bottom: 5px;"> <div style="border: 1px solid black; padding: 5px; width: 20%;">Replace parts described above.</div> <div style="border: 1px solid black; padding: 5px; width: 20%;">Replace rack oil seal.</div> <div style="border: 1px solid black; padding: 5px; width: 20%;">Replace parts described above.</div> <div style="border: 1px solid black; padding: 5px; width: 20%;">Replace gear housing tube.</div> </div> <div style="border: 1px solid black; padding: 5px; margin-bottom: 5px;">Measure pinion rotating torque.</div> <div style="border: 1px solid black; padding: 5px; margin-bottom: 5px;">Adjust adjusting screw.</div> <div style="border: 1px solid black; padding: 5px;">Measure rack starting force and pinion rotating torque.</div>			
Service parts to be prepared	<ul style="list-style-type: none"> • Pinion seal kit 	<ul style="list-style-type: none"> • Gear housing seal kit 	<ul style="list-style-type: none"> • Rack oil seal • Pinion seal kit 	<ul style="list-style-type: none"> • Gear housing seal kit

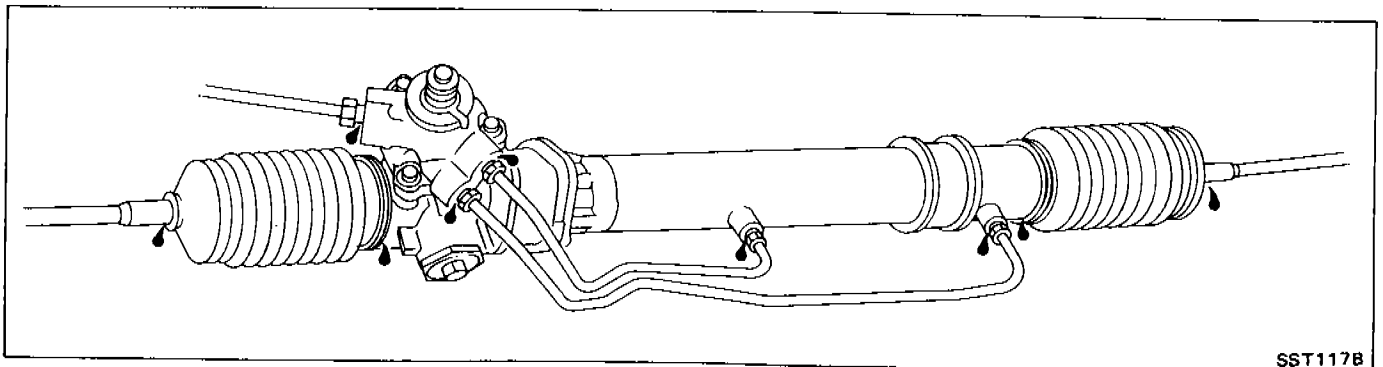

SST117B

POWER STEERING GEAR AND LINKAGE (Model PR24SC and PR26SC)

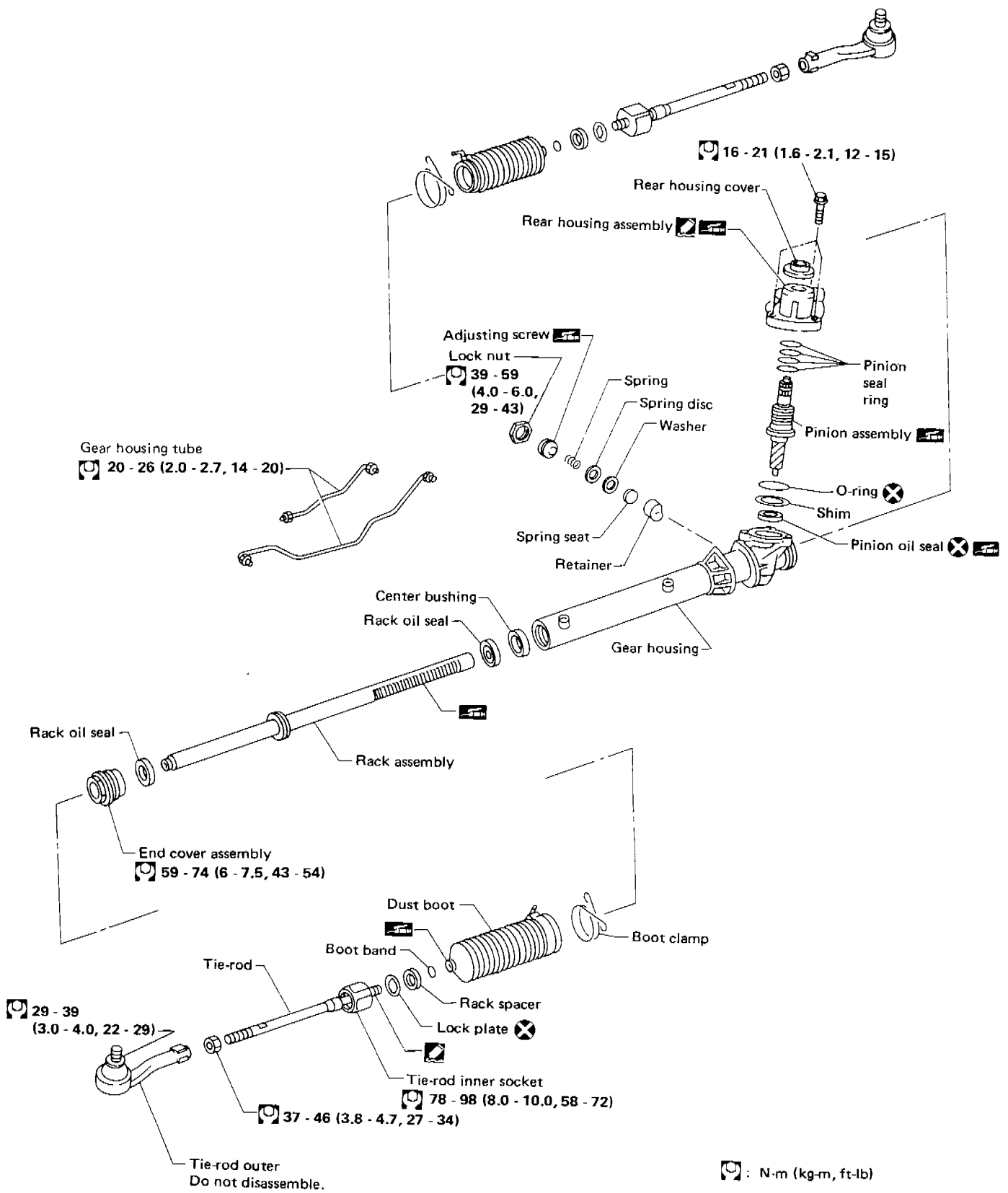

SST118B

POWER STEERING GEAR AND LINKAGE (Model PR24SC and PR26SC)

Disassembly

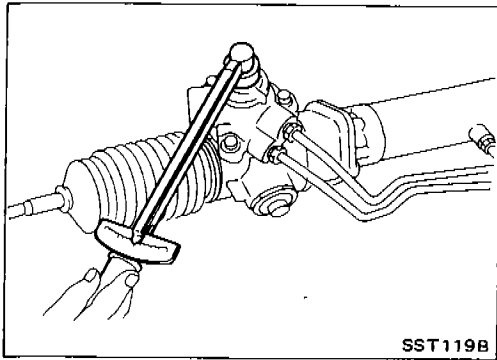

1. Prior to disassembling, measure pinion rotating torque. Record the pinion rotating torque as a reference.
 - Before measuring, disconnect gear housing tube and drain fluid.
 - Use soft jaws when holding steering gear housing. Handle gear housing carefully, as it is made of aluminum. Do not grip cylinder in a vise.
2. Remove pinion gear.
 - Be careful not to damage pinion gear when removing pinion seal ring.

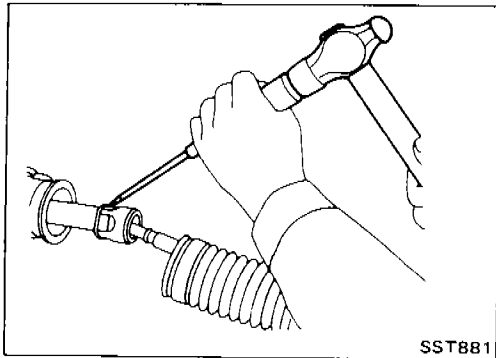

3. Remove tie-rod outer sockets and boots.
4. Loosen tie-rod inner socket by prying up staked portion, and remove socket.
5. Remove retainer.
6. Remove pinion assembly.

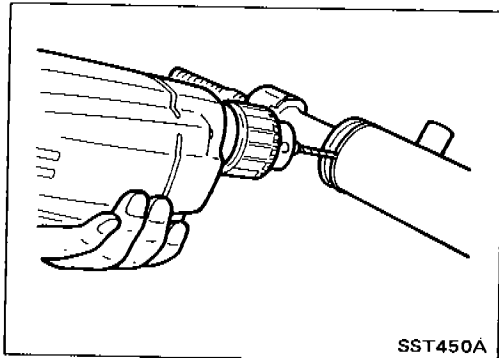

7. Drill staked portion of gear housing end with drill of 2 to 2.5 mm (0.079 to 0.098 in) diameter, until the staking is eliminated.

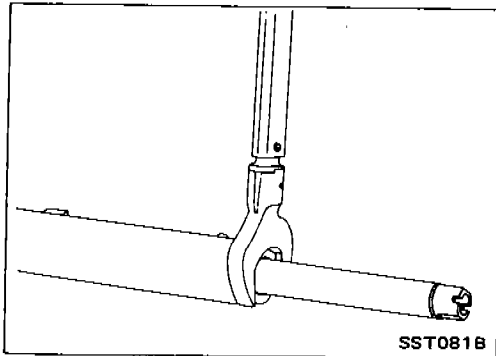

8. Remove end cover assembly with suitable tool.
9. Draw out rack assembly.

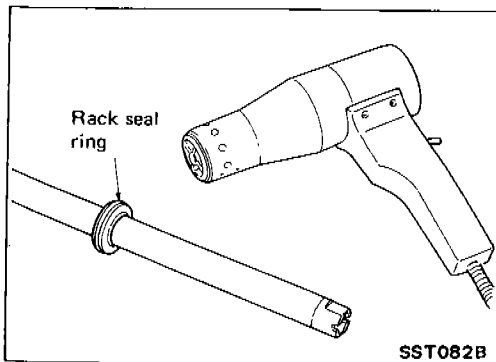

10. Remove rack seal ring.
 - Using a heat gun, heat rack seal to approximately 40°C (104°F).
 - Remove rack seal ring. Be careful not to damage rack.
 - Replace rack seal ring and O-ring with new ones.

POWER STEERING GEAR AND LINKAGE (Model PR24SC and PR26SC)

Disassembly (Cont'd)

11. Remove center bushing and rack oil seal using tape wrapped socket and extension bar.

Do not scratch inner surfaces of pinion housing.

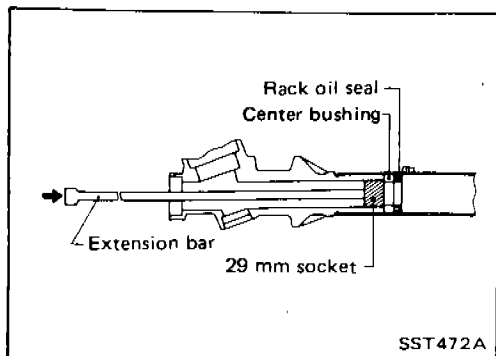

Assembly

1. Using a heat gun, heat rack seal ring (made of Teflon) to approximately 40°C (104°F) and install it onto rack with your hand.

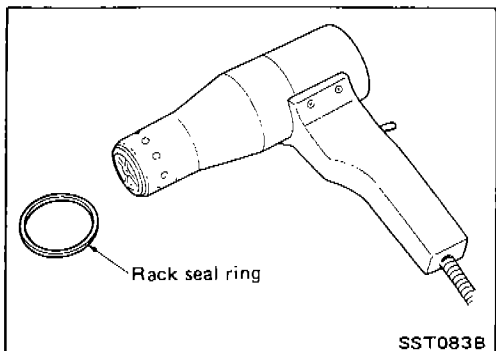

● Using Tool, compress periphery of rack seal ring (made of Teflon) to position and secure it on rack.

Always insert the tool from the rack gear side.

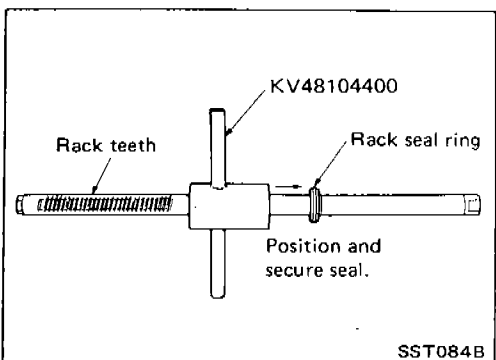

2. Insert rack oil seal.

● Place plastic film into rack oil seal to prevent damage by rack teeth.

● Always remove plastic film after rack oil seal is positioned properly.

● Make sure lips of rack oil seal face each other.

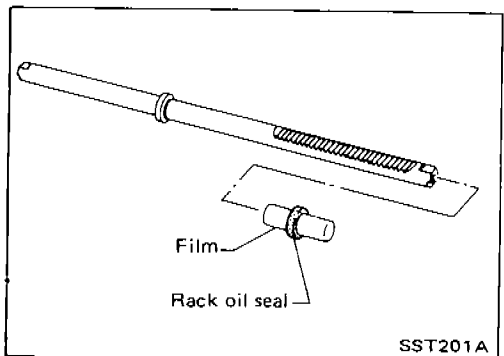

3. Install center bushing and rack oil seal with rack assembly.

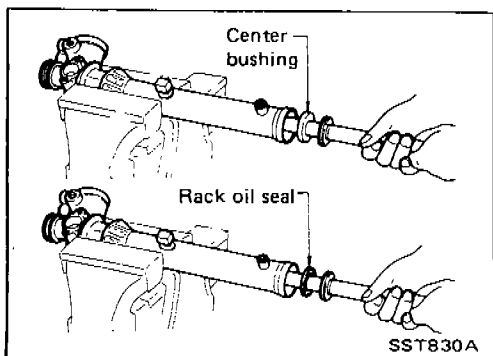

POWER STEERING GEAR AND LINKAGE (Model PR24SC and PR26SC)

Assembly (Cont'd)

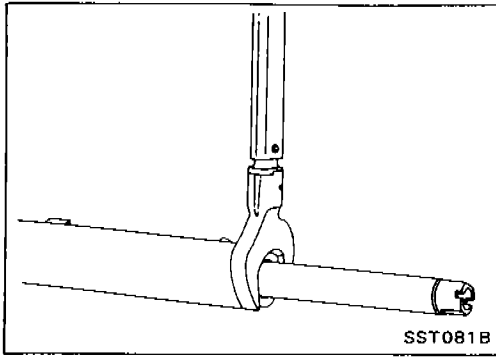

4. Tighten end cover assembly with suitable tool.

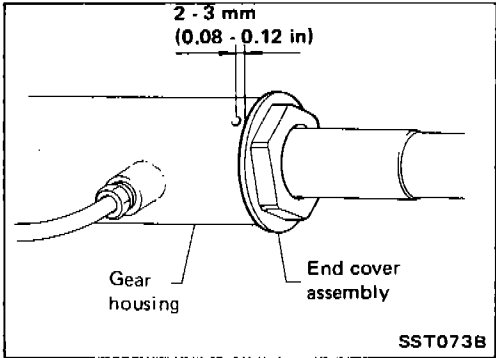

5. Fasten end cover assembly to gear housing by staking.

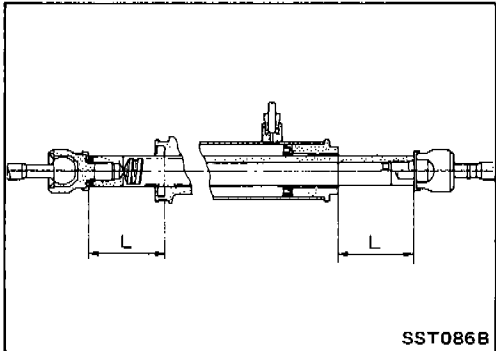

6. Set rack gear in neutral position.
Measured length "L":
Refer to S.D.S.

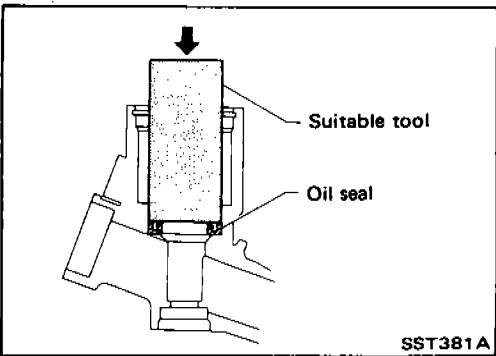

7. Coat seal lip of oil seal with multi-purpose grease and install new pinion oil seal to pinion housing of gear housing with suitable tool.
 - Make sure lip of oil seal faces up when installed.

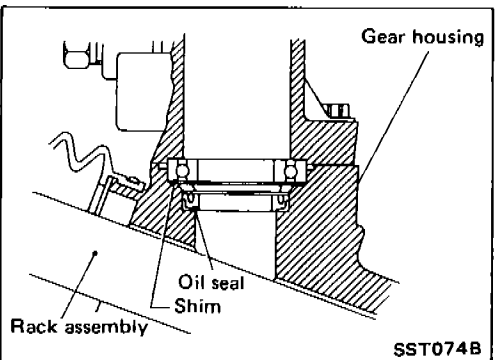

8. Install pinion bearing adjusting shim(s).
 - Whenever pinion assembly, gear housing and rear housing are disassembled, replace shim(s) with new ones. Always use the same number of shim(s) when replacing.

POWER STEERING GEAR AND LINKAGE (Model PR24SC and PR26SC)

Assembly (Cont'd)

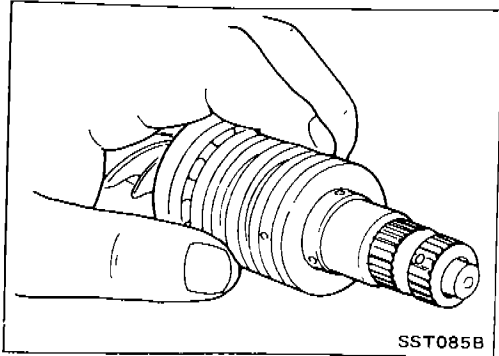

9. Install pinion seal ring on pinion gear assembly.
 - Using a heat gun, heat pinion seal ring to approximately 40°C (104°F) before installing it onto pinion gear assembly.
 - Make sure pinion seal ring is properly settled in valve groove.

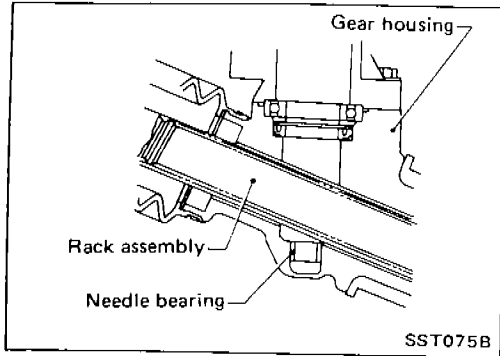

10. Apply a coat of multi-purpose grease to needle bearing roller and oil seal lip before installing pinion assembly in gear housing.

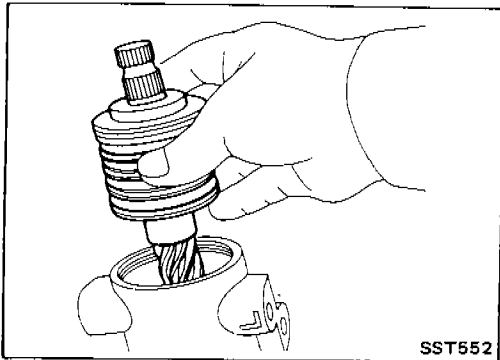

11. Install pinion assembly to pinion housing of gear housing.
Be careful not to damage pinion oil seal.

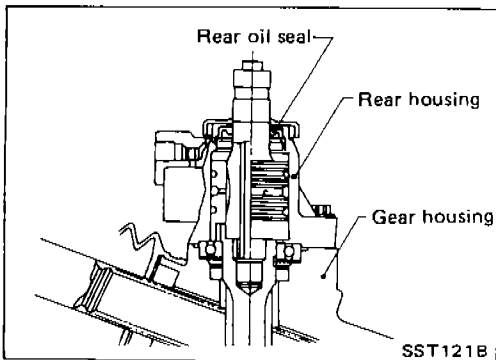

12. Apply a coat of multi-purpose grease to rear oil seal lip before installing rear housing.

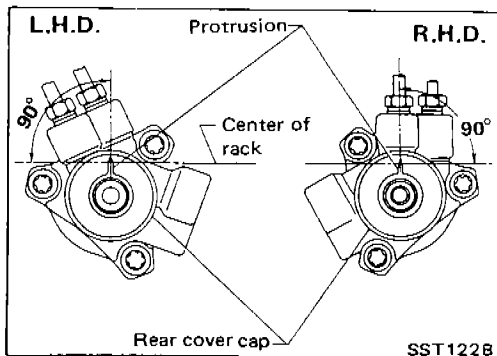

13. Install rear cover cap so that protrusion of rear housing cover is positioned as shown in figure at left.
Be careful not to damage worm ring and oil seal.

POWER STEERING GEAR AND LINKAGE (Model PR24SC and PR26SC)

Assembly (Cont'd)

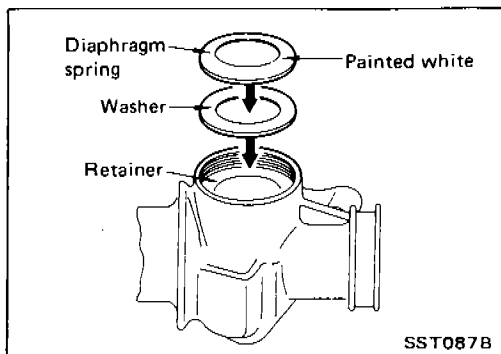

14. Install diaphragm spring at retainer.

- Always install retainer, spring washer and diaphragm spring in that order.
- Make sure convex end (painted white) of diaphragm spring faces outward when installing.

15. Install retainer spring and adjusting screw temporarily.

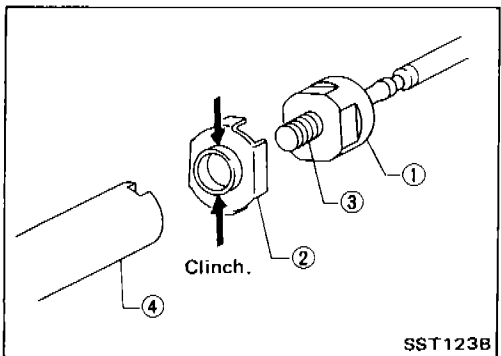

16. Install new lock plate.

- Attach lock plate ② to side rod inner socket ①.
- Apply locking sealant to inner socket threads ③. Screw inner socket into rack ④ and tighten to specified torque.
- Clinch two places of lock plate at rack's groove.

CAUTION:

To prevent scratching the boot, remove burrs from lock plate.

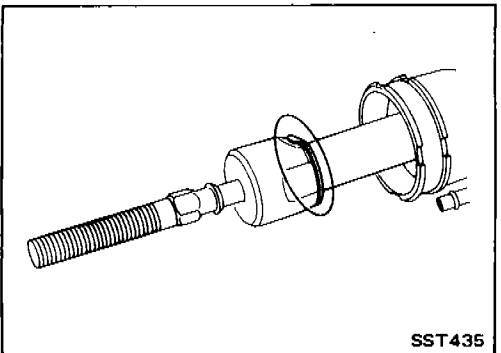

17. Tighten inner socket and securely bend lock plate at 2 cutout portions of inner socket.

To prevent damage to boot, remove burrs after bending lock plate.

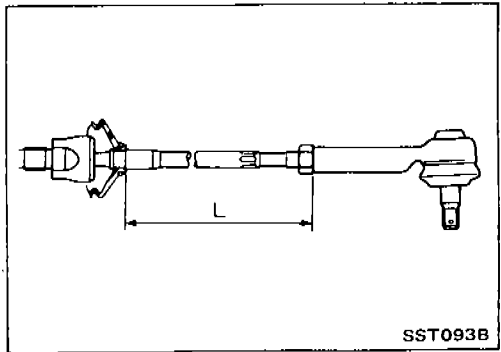

18. Tighten outer socket lock nut.

Tie-rod length "L":

Refer to S.D.S.

Screwed length "Q":

32.2 mm (1.268 in) or more

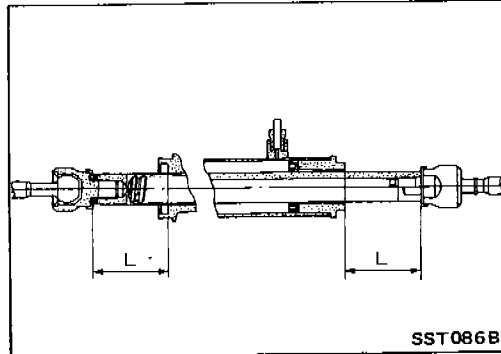

19. Measure rack stroke.

Measured length "L":

Refer to S.D.S.

POWER STEERING GEAR AND LINKAGE (Model PR24SC and PR26SC)

Assembly (Cont'd)

20. Before installing boot, coat the contact surfaces between boot and tie-rod with grease.

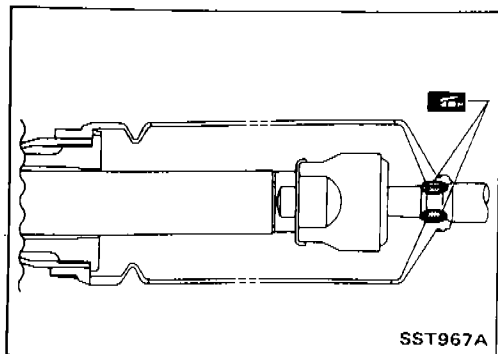

21. Install boot clamps.

- To install, wrap boot clamp around boot groove twice. Tighten clamp by twisting rings at both ends 4 to 4-1/2 turns with screwdriver while pulling with a force of approx. 98 N (10 kg, 22 lb).

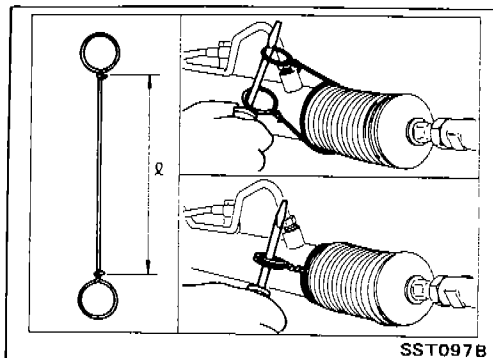

- Install boot clamp so that it is to the rear of the vehicle when gear housing is attached to the body. (This will prevent interference with other parts.)

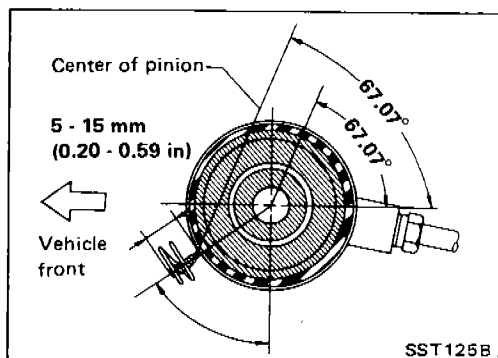

- Twist boot clamp in the direction shown in figure at left.

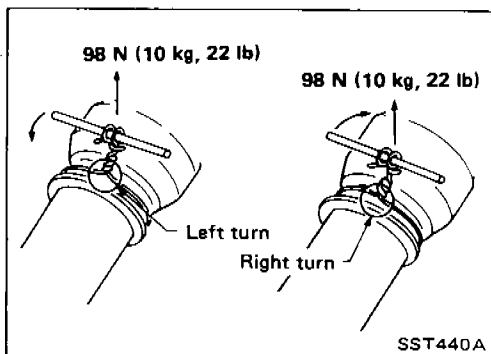

- After twisting boot clamp, bend twisted and diagonally so it does not contact boot.

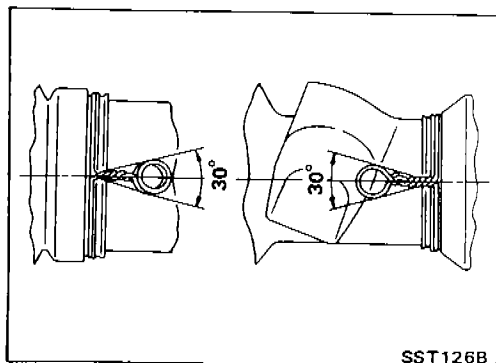

POWER STEERING GEAR AND LINKAGE (Model PR24SC and PR26SC)

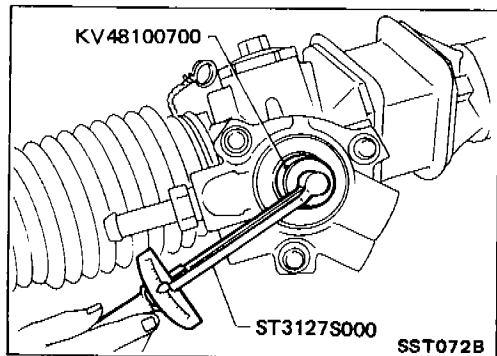
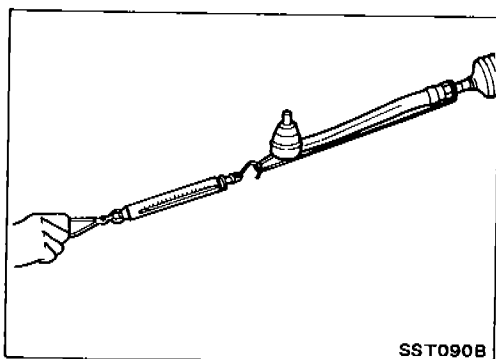
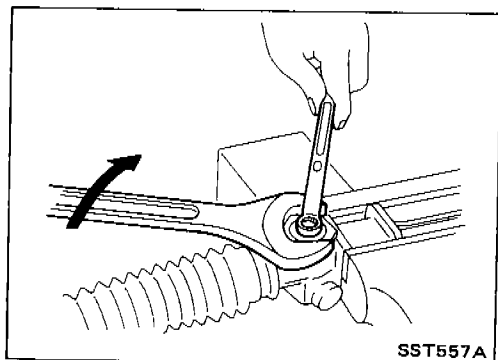
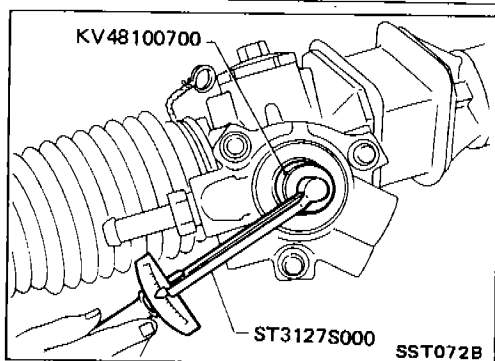
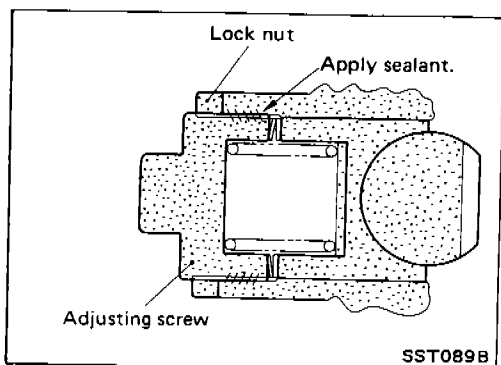

Adjustment

Adjust pinion rotating torque as follows:

1. Set gears to Neutral without fluid in the gear.
2. Coat the adjusting screw with locking sealant and screw it in.
3. Lightly tighten lock nut.
4. Tighten adjusting screw to a torque of 4.9 to 5.9 N·m (50 to 60 kg-cm, 43 to 52 in-lb).
5. Loosen adjusting screw, then retighten it to 0.05 to 0.20 N·m (0.5 to 2 kg-cm, 0.43 to 1.74 in-lb).
6. Move rack over its entire stroke several times.
7. Measure pinion rotating torque within the range of 180° from neutral position.
Stop the gear at the point of maximum torque.
8. Loosen adjusting screw, then retighten it to 4.9 to 5.9 N·m (50 to 60 kg-cm, 43 to 52 in-lb).
9. Loosen adjusting screw by 40° to 60°.
10. Prevent adjusting screw from turning, and tighten lock nut to specified torque.
11. Check steering gear for rack sliding frictional force.
Around neutral point of rack stroke
±5.5 mm (±0.217 in):
122.6 - 166.7 N (12.5 - 17 kg, 27.6 - 37.5 lb)
Except for neutral point:
122.6 - 186.3 N (12.5 - 19 kg, 27.6 - 41.9 lb)
If sliding frictional force is out of specification, repeat the adjustment procedure, starting from No. 4.
After the readjustment, if sliding force is still out of specification, steering gear is damaged.
12. Measure pinion rotating torque within the range of ±100° from the neutral point.
Average rotating torque
[(Max. measured value + Min. measured value) x 0.5]:
0.8 - 1.3 N·m (8 - 13 kg-cm, 6.9 - 11.3 in-lb)
Maximum torque increment:
Less than 0.4 N·m (4 kg-cm, 3.5 in-lb)
Except for above mentioned measuring range:
Maximum rotating torque
1.9 N·m (19 kg-cm, 16 in-lb)
Maximum torque increment
Less than 0.6 N·m (6 kg-cm, 5.2 in-lb)

POWER STEERING GEAR AND LINKAGE (Model PR24SC and PR26SC)

Adjustment (Cont'd)

- If pinion rotating torque is not within specification, readjust it.
- After the readjustment, if pinion rotating torque is still out of specification, steering gear is damaged.

Inspection

Thoroughly clean all parts in cleaning solvent or automatic transmission fluid "DEXRON™ Type", and blow dry with compressed air, if available.

BOOT

Check condition of boot. If cracked excessively, replace it.

RACK

Thoroughly examine rack gear. If damaged, cracked or worn, replace it.

PINION ASSEMBLY

- Thoroughly examine pinion gear. If pinion gear is damaged, cracked or worn, replace it.
- Inspect bearings to see that they roll freely and are free from cracked, pitted, or worn balls, rollers and races. Replace if necessary.

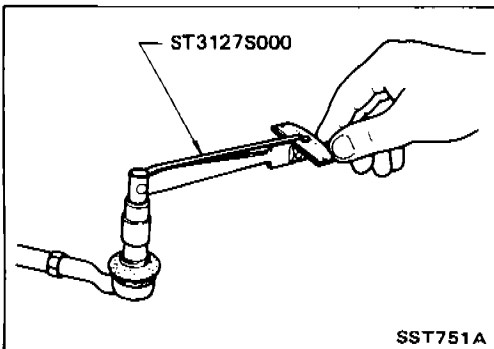
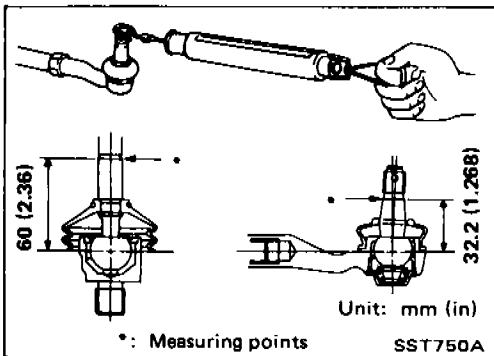

TIE-ROD OUTER AND INNER SOCKET

- Check ball joint for swinging force.

Tie-rod outer ball joint:

9.12 - 91.30 N

(0.93 - 9.31 kg, 2.05 - 20.53 lb)

Tie-rod inner ball joint:

8.14 - 122.6 N

(0.83 - 12.5 kg, 1.83 - 27.6 lb)

- Check ball joint for rotating torque.

Tie-rod outer ball joint:

0.29 - 2.94 N·m

(3.0 - 30.0 kg-cm, 2.6 - 26.0 in-lb)

Tie-rod inner ball joint:

7.4 N·m (75 kg-cm, 65 in-lb) or less

POWER STEERING GEAR AND LINKAGE (Model PR24SC and PR26SC)

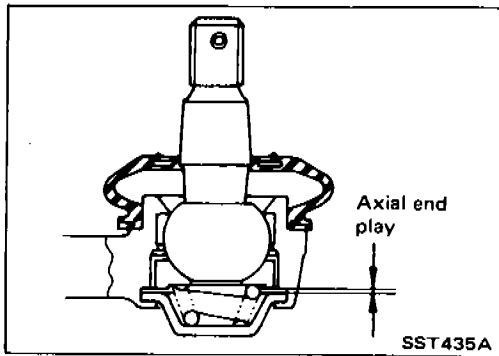

Inspection (Cont'd)

- Check ball joint for axial end play.
 - Tie-rod outer ball joint:**
0.5 mm (0.020 in) or less
 - Tie-rod inner ball joint:**
0 mm (0 in)
- Check condition of dust cover. If cracked excessively, replace it.

GEAR HOUSING CYLINDER

Check gear housing cylinder for scratches or other damage. Replace if necessary.

POWER STEERING OIL PUMP

Disassembly and Assembly

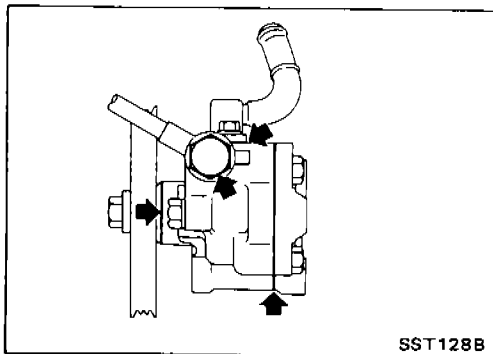
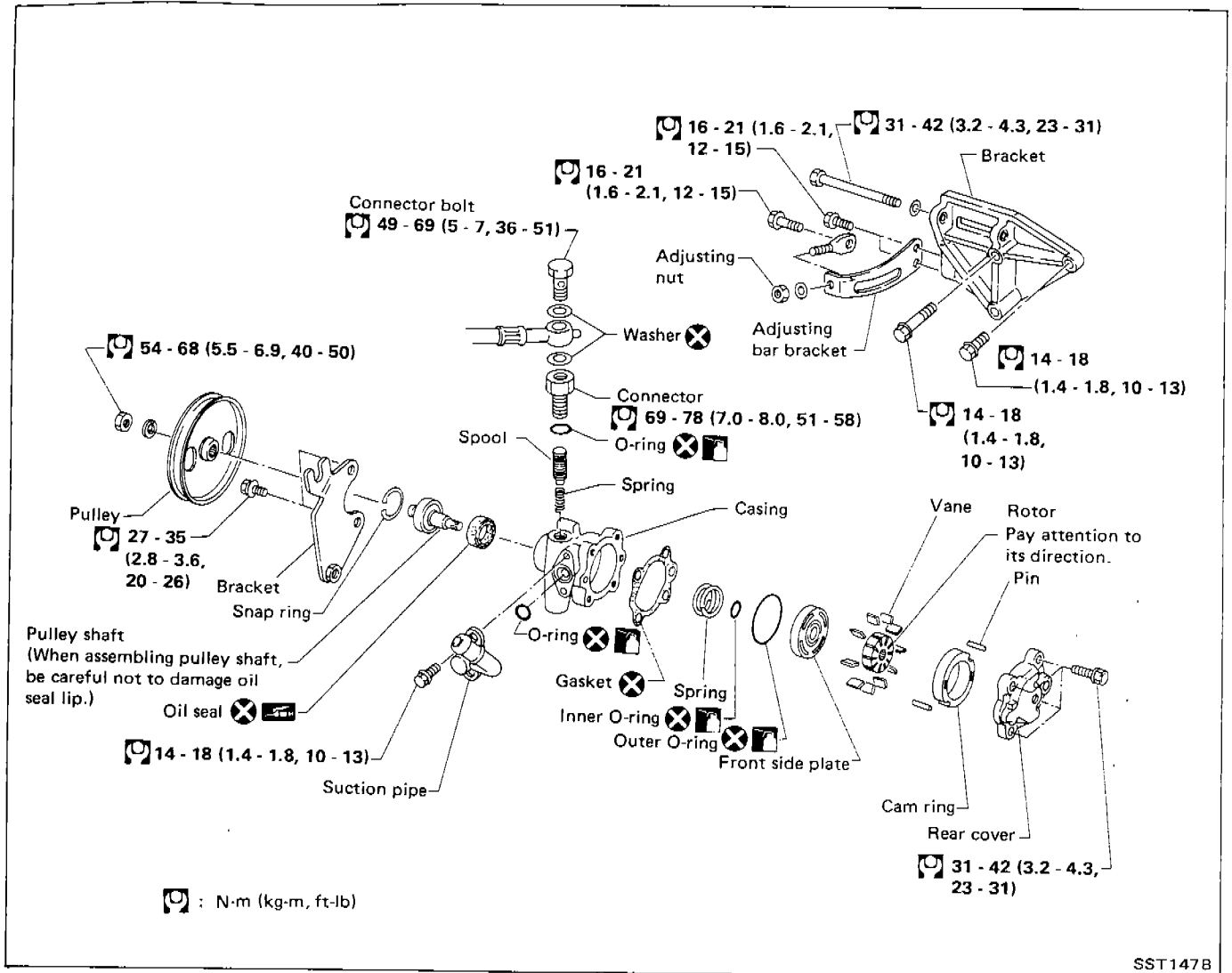

Pre-disassembly Inspection

Disassemble the power steering oil pump only if the following items are found.

- Oil leak from any point shown in the figure
- Deformed or damaged pulley

Disassembly

CAUTION:

- Parts which can be disassembled are strictly limited. Never disassemble parts other than those specified.
- Disassemble in as clean a place as possible.
- Clean your hands before disassembly.
- Do not use rags; use nylon cloths or paper towels.
- Follow the procedures and cautions in the Service Manual.
- When disassembling and reassembling, do not let foreign matter enter or contact the parts.

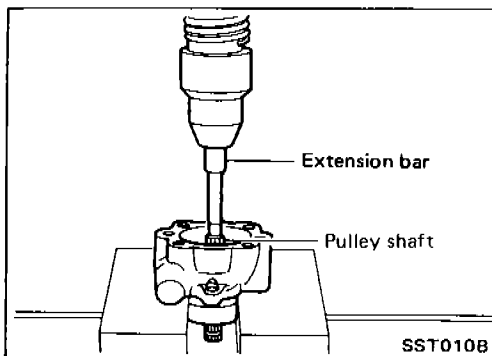

- Remove snap ring, then draw pulley shaft out.
Be careful not to drop pulley shaft.

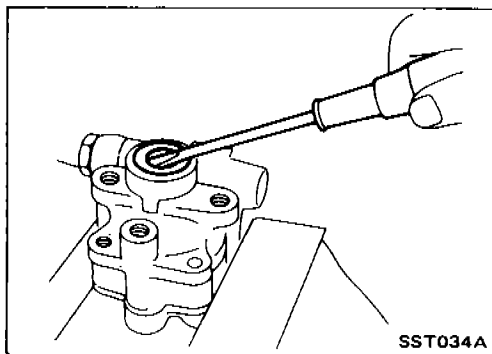

- Remove oil seal.
Be careful not to damage front housing.

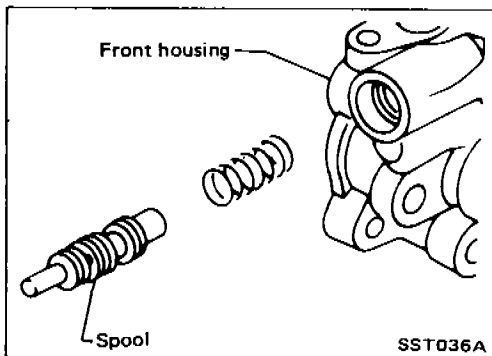

- Remove connector.
Be careful not to drop spool.

Inspection

PULLEY AND PULLEY SHAFT

- If pulley is cracked or deformed, replace it.
- If an oil leak is found around pulley shaft oil seal, replace the seal.
- If serration of pulley or pulley shaft is deformed or worn, replace it.

POWER STEERING OIL PUMP

Assembly

Assemble oil pump in the reverse order of disassembly, noting the following instructions.

- Before installation, coat the O-rings and oil seal with A.T.F.*
 - Make sure O-rings and oil seal are properly installed.
 - When assembling vanes to rotor, rounded surfaces of vanes must face cam case side.
 - Always install new O-rings and oil seal.
 - Be careful of oil seal direction.
- *: Automatic Transmission Fluid

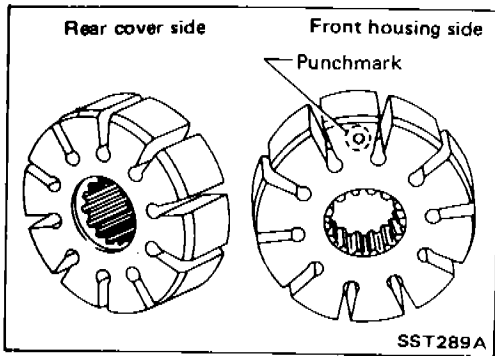

- Pay attention to the direction of rotor.

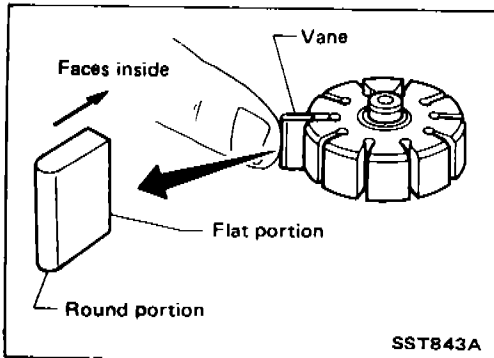

- Install vanes properly.

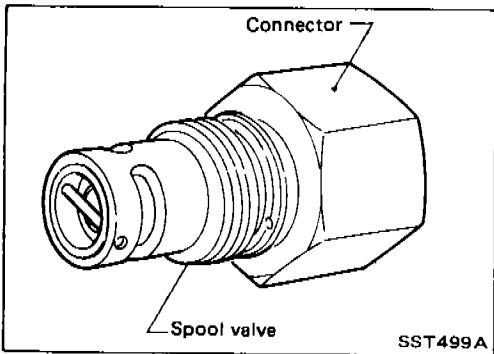

CAUTION:
Do not remove spool valve from connector.

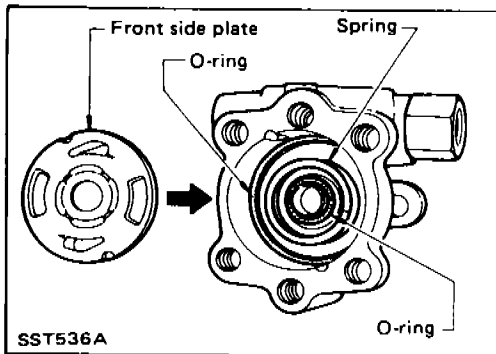

- Apply A.T.F.* to O-ring.
- *: Automatic Transmission Fluid

POWER STEERING OIL PUMP

Assembly (Cont'd)

- Insert pin ② into pin groove ① of front housing and rotor. Then install cam ring ③ as shown at left.

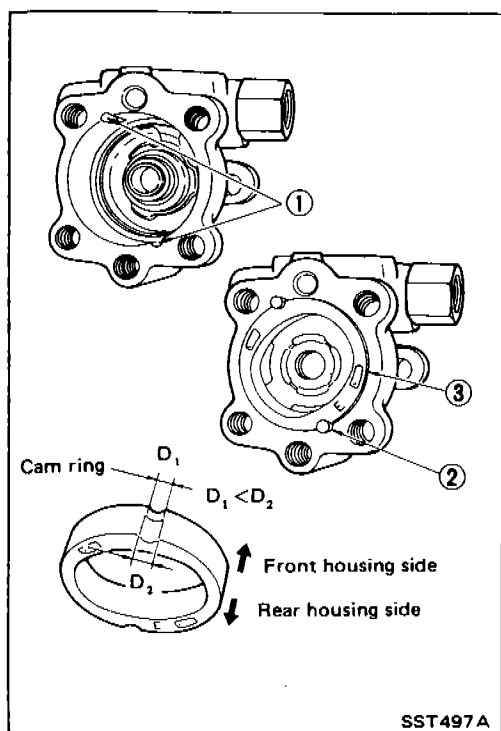

SERVICE DATA AND SPECIFICATIONS (S.D.S.)

General Specifications

Model	R.H.D.	L.H.D.	
		Except Europe	Europe
Steering model	Power steering		
Steering gear type	PR24SC		PR26SC
Turn of steering wheel (Lock to lock)	3.1		3.2
Steering column type	Collapsible, tilt	Collapsible, jumping tilt	

Inspection and Adjustment

GENERAL

Steering wheel axial play	mm (in)	0 (0)
Steering wheel play	mm (in)	0 - 35 (0 - 1.38)

STEERING COLUMN

Model	R.H.D.	L.H.D.
Steering column length "L ₁ " mm (in)	715.2 - 716.8 (28.16 - 28.22)	652.9 - 654.5 (25.70 - 25.77)
Steering column lower shaft length "L ₂ " mm (in)	273.7 (10.78)	324.7 (12.78)

R.H.D. and L.H.D.

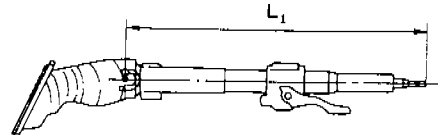

SST098B

R.H.D.

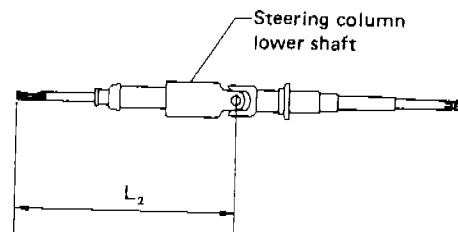

SST115B

L.H.D.

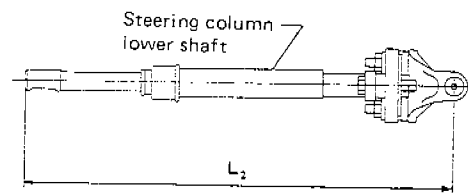

SST146B

SERVICE DATA AND SPECIFICATIONS (S.D.S.)

Inspection and Adjustment (Cont'd)

STEERING GEAR AND LINKAGE

Item	Steering gear type	PR24SC	PR26SC
Tie-rod outer ball joint	Swinging force* N (kg, lb)	9.12 - 91.30 (0.93 - 9.31; 2.05 - 20.53)	
	Rotating torque N·m (kg-cm, in-lb)	0.29 - 2.94 (3.0 - 30.0, 2.6 - 26.0)	
	Axial end play mm (in)	0.5 (0.020)	
Tie-rod inner ball joint	Swinging force* N (kg, lb)	8.14 - 122.6 (0.83 - 12.5, 1.83 - 27.6)	
	Rotating torque N·m (kg-cm, in-lb)	7.4 (75, 65) or less	
	Axial end play mm (in)	0 (0)	
Tie-rod standard length "L" mm (in)		174.8 (6.88)	

*: Measuring point

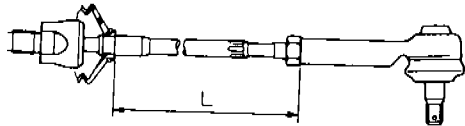

SST093B

Pinion gear preload (Average) N·m (kg-cm, in-lb)	0.78 - 1.27 (8.0 - 13.0, 6.9 - 11.3)	
Rack stroke "L" mm (in)	68.5 (2.697)	66.0 (2.598)

PR24SC

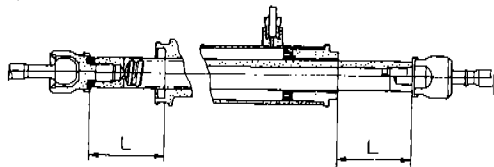

SST086B

PR26SC

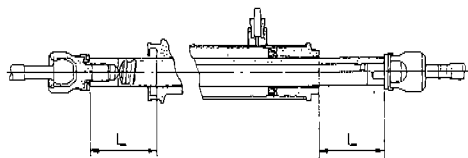

SST164B

POWER STEERING

Rack sliding force N (kg, lb)	166.7 - 255.6 (17.0 - 23.0, 37.5 - 50.7)	
Steering wheel turning force (Measured at one full turn from neutral) N (kg, lb)	39 (4, 9) or less	
Normal operating temperature of power steering fluid °C (°F)	60 - 80 (140 - 176)	
Fluid capacity (Approximate) ℓ (Imp qt)	0.9 (3/4)	
Oil pump maximum pressure kPa (bar, kg/cm ² , psi)	6,865 (68.6, 70, 995)	